

SteelStacks Performing Arts Center | Bethlehem, Pennsylvania

Thesis Proposal

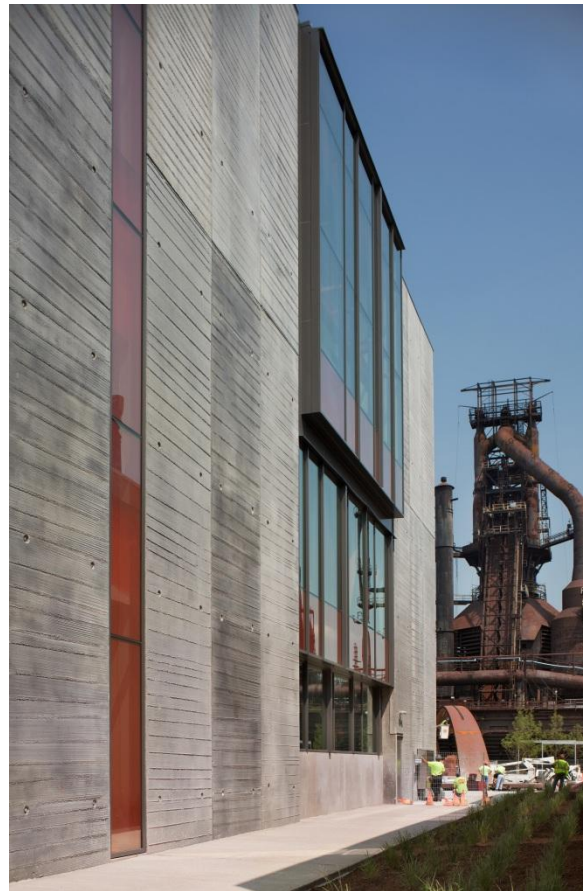

Sarah A Bednarcik
Advisor: Dr. Linda Hanagan
14 December 2012
Revised: 25 February 2013

Executive Summary

The purpose of this report is to provide a solution and detailed process for the scenario that has developed concerning the structural system of the Steel Stacks Performing Arts Center (SSPAC), while outlining the tasks, tools, and schedule for the proposed solution. The SSPAC is a 64-foot, 4 story, 67,000 square foot arts and cultural center in Bethlehem, Pennsylvania. The existing lateral system consists of braced frames and shear walls in the East-West direction and shear walls in the North-South direction, with concrete slabs taking additional lateral loads as the floor diaphragms.

A scenario has been created in which the architect would like to explore an alternative option, and the building is required to be built in reinforced concrete. A comparison of the existing system and the redesigned concrete system will be developed for a thorough understanding of the benefits and disadvantages of each. Through the observations made in Technical Report II, this is a viable system redesign for comparison to the existing system. Other alternatives, such as a precast plank floor system, in Technical Report II have been disqualified due to the inconsistency in bay layouts.

The structural depth solution to this scenario implements additional shear walls to replace the existing braced frames as part of the lateral system. The gravity system will be redesigned as a reinforced concrete system, with minimization of cost and waste as considerations throughout redesign. Floor diaphragms will be evaluated in larger bays for the use of prestressed concrete design.

The solution for the structural redesign will impact the architecture and acoustics of the spaces. With both aesthetics and acoustics being important factors in the original design, they are also necessary considerations for the redesign. Public spaces will be impacted by the structural changes due to acoustic issues, such as in the stage and Musikfest Café area. With the floor system being redesigned, acoustical performance of the existing and new designs will be studied and taken into account in a comparison of the final gravity system. In architectural design, the public spaces and facade will be altered due to the wall and gravity systems being redesigned. For this to be thoroughly evaluated, an architectural model will be utilized to compare the existing and redesigned spaces, with major impacts being studied for possible alteration.

In addition, MAE coursework will be included in this thesis project, and has been incorporated into this proposal. Material from AE 530, *Computer Modeling of Building Structures*, and CE 543, *Prestressed Concrete Behavior and Design*, will be utilized to provide a more complete project, and the implementation has been elaborated on in this report.

In preparation for the thesis project, this proposal includes the tasks and tools used for each aspect of the proposed solution, as well as a detailed schedule outlining the specific steps required to complete the redesign process.

Table of Contents

Executive Summary.....	1
Purpose	3
Introduction	3
General Structural Information.....	6
Structural System Overview.....	6
Foundation.....	6
Floor System.....	7
Framing System.....	7
Lateral System.....	9
Problem Statement.....	11
Proposed Solution.....	11
Breadth Study	12
Acoustics:	12
Architecture:	12
MAE Component.....	13
Tasks & Tools.....	14
Timetable	15
Conclusion.....	16

Purpose

The purpose of this report is to propose a particular scenario that has developed for the SteelStacks Performing Arts Center. This problem necessitates redesign of different aspects of the building, and a proposed solution is elaborated in the following report. To display capabilities of accomplishing this solution, the solution method and timeline are also elaborated. Precursory information has been presented to provide a better understanding of the existing building and design information.

Introduction

The SSPAC is a new arts and cultural center designed to fit into the historic yet modern atmosphere of its location on the site of the previous Bethlehem Steel Corporation and situated near downtown Bethlehem. The owner is committed to uniting the community through the transformation of this brownfield into a revitalized historic site with LEED Silver status for the SSPAC is in progress. This has been achieved architecturally and structurally through the raw aesthetics of the steel and concrete structure, sitting amongst the skeletons of Bethlehem Steel as shown in Figure 1.

Exposed structural steel and large atrium spaces in the SSPAC imitate the existing warehouses and steel mill buildings for integration into the site. Yet in contrast, the SSPAC has an outlook on the community, with a large glass curtain wall system opening the interior atriums to the surrounding site. These atriums also look introspectively, uniting the various floors together as part of the mission to unite the community. These

open spaces vary in size, location, and specific use, and yet all deliver similar results. The first floor consists of public spaces, such as a commons area open to above, and cinema spaces. The second floor is similar, with a mezzanine open to the common area on the first floor, as seen in the second floor plan in Figure 2. The third and fourth floors consist of a stage and small restaurant connecting the two floors via an atrium, and a cantilevered terrace adjoining the third floor, as seen in the third floor plan in Figure 3. The balcony portion of the restaurant on the fourth floor overlooks the third floor stage, as seen via outline on the third floor plan. Both the third and fourth floors have back-of-house spaces such as kitchens, offices, storage, and green rooms that service the public spaces.

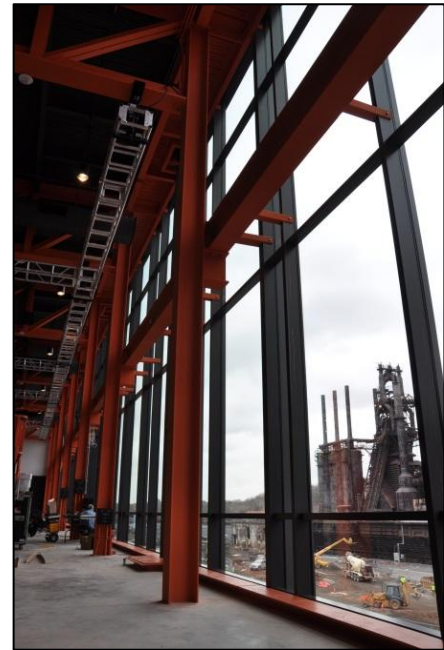

Figure 1: Interior atrium space, highlighting opening structural plan.

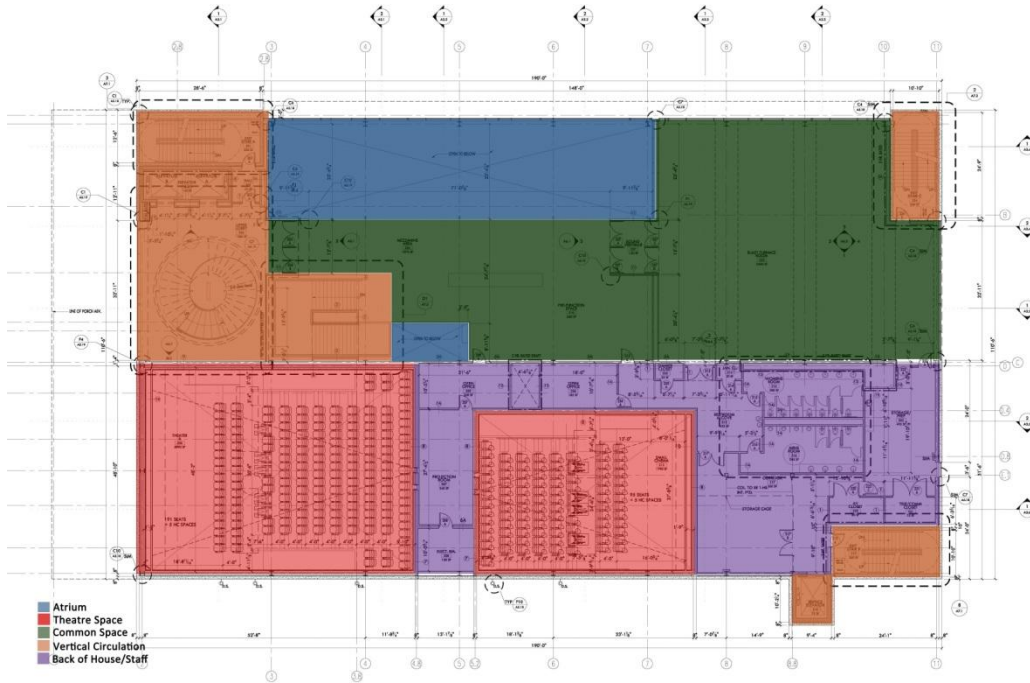

Figure 2: Floor Plan from A2.2

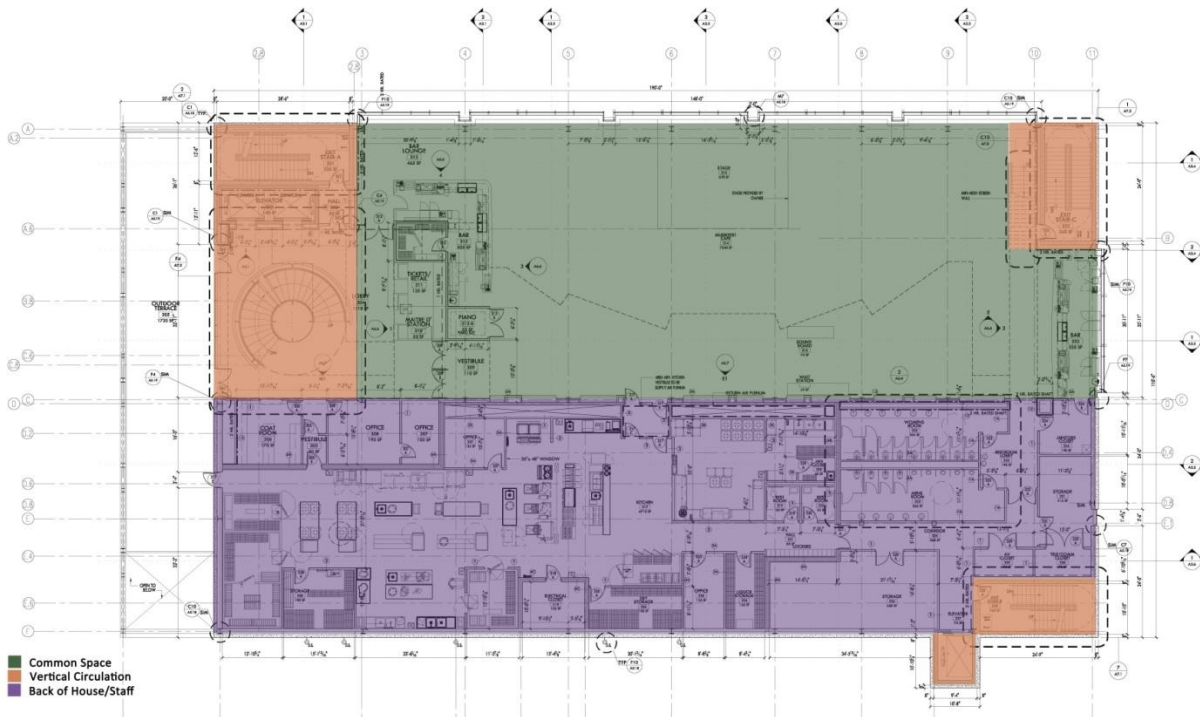

Figure 3: Third Floor Plan from A2.3

This \$48 million project is approximately 67,000 square feet and is four stories above grade, with an integrated steel and concrete panel structural system. With a total building height of 64 feet, each level has a large floor-to-floor height, allowing for more open spaces and larger trusses to span the undersides of each floor system, mirroring the style of trusses found in an original warehouse. The spaces in the SSPAC include creative commons, theatres, a café, stage and performance area, production rooms, offices, and kitchens.

The main features of the façade are precast concrete panels with a textured finish, mimicking the aesthetics of the surrounding buildings, as well as a glass curtain wall system. The curtain wall system includes low E and fritted glazing along the northern facing wall that allows light to enter throughout the atrium common spaces on all floors. This is supported by the steel skeleton, which divides the building structurally into two acoustic portions, keeping vibrations from the north and south halves of the building from transferring, as seen in Figure 3.

While the SSPAC does not have any highlighted features that distinctly call to its LEED Silver certification, the integration towards sustainability of building design, use, and construction has been thoroughly developed in the structure and site. The overall building aesthetics and structural system can be attributed partially to sustainability, but also to the historical values that the site brings and the future purpose of the space integrating into these focuses.

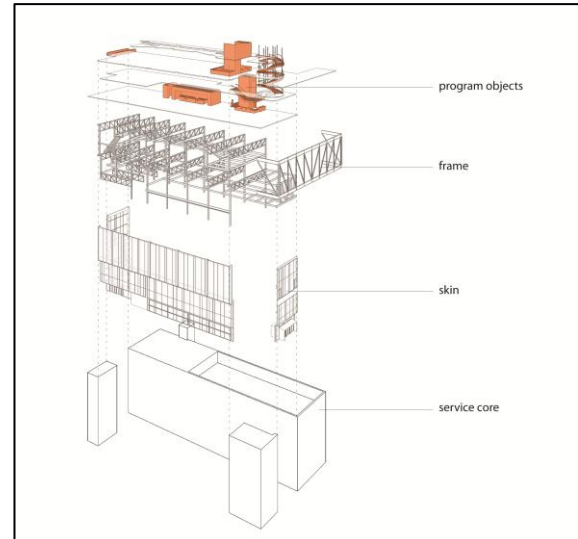

Figure 4 : Image displaying the separation of spaces through the structural design.

Courtesy of Barry Isett, Inc. & Assoc.

General Structural Information

This section provides a brief overview of the SSPAC in terms of the structural system, design codes, and materials, detailing the structural elements and factors associated with the structure's design and performance.

Structural System Overview

The structure of the SteelStacks Performing Arts Center consists of steel framing on a foundation of footings and column piers. Precast concrete panels and braced frames make up the lateral framing. The second, third, and fourth floors consist of normal weight concrete on metal decking, supported by a beam and truss system. The roof consists of an acoustical decking and slab system.

Foundation

French & Parrello Associates conducted field research on May 20, 2009, collecting the plan and topographic information shown on the civil drawings. The site of the SSPAC had an existing building, to be fully removed before start of construction. This demolition included the removal of the foundation and slab on the west side of the site. The location of an underground tunnel directly under the existing building was also taken into consideration when designing the foundation system for the SSPAC. The SSPAC is built above the original building portion that was demolished.

Following the survey findings, provisions were supplied for instances of sink holes, accelerated erosion, and sediment pollution. The soil bearing pressure has been recommended on the subsequent plans as a minimum of 3000 psf, with precautions during construction required due to these results.

The foundation was then determined to be a system of column piers and footings supporting a slab-on grade. The column footings varying in size from 3'0" x 3'0" to 20'0" x 20'0" and vary in depth from 1'0" to 4'2". The variation in dimensions and depths of the column footings is due to the building design as well as the soil and other existing conditions that lead to settlement and strength issues. The foundations allow for a transfer of gravity loads into the soil, as seen in Figure 5, through connection with the first floor system and precast concrete panels.

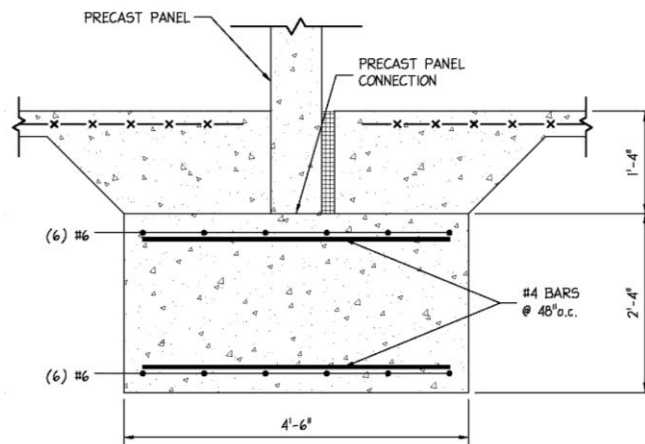
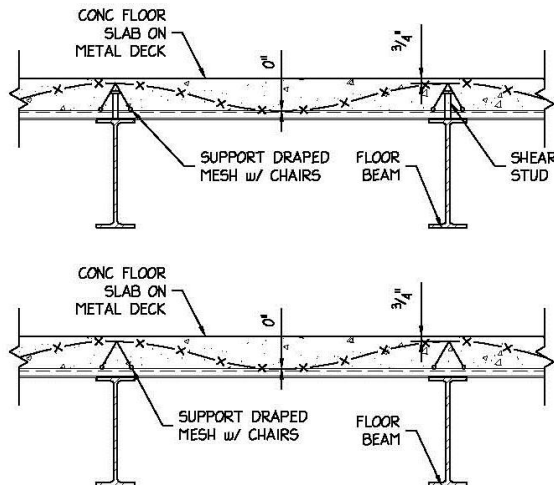

Figure 5 : Section of foundation to precast panel connection from S1.0.

Floor System

The first floor system is directly supported by the foundation of the building, with a 4" reinforced concrete slab sitting on top of a sub-floor composed of 4-6 inches of compacted gravel or crushed stone. The second and fourth floors consist of a 5" concrete slab on 2"x20 GA galvanized composite metal decking. This decking is supported by composite beams for smaller spans for the back-of-house spaces,



TYP. COMPOSITE SLAB CONSTRUCTION

SCALE: $\frac{3}{4}'' = 1'-0''$

while exposed trusses support this floor system for larger, public spaces. Uniquely, the third floor is comprised of an 8" concrete slab on 2"x16GA galvanized composite metal decking. This difference in slab thickness is due to acoustics of the spaces, requiring more vibration and sound isolation around the stage for band performances. The roof is a galvanized epicore 20GA roof deck, an acoustical decking and slab system.

Figure 6 : Typical composite slab section from S2.8

Metal decking is connected to beams and girders with metal studs where appropriate.

Decking is based on products from United Steel Deck, Inc. Depending on location, decking varies between roof decking, composite, and non-composite decking, but all decking is welded to supports and has a minimum of a 3-span condition. A section of the composite slab for this building can be seen in Figure 6.

Framing System

Supporting the floor systems are series of beams, girders, and trusses. Floor beams are spaced at a maximum of 7'6". The beams are also generally continuously braced, with $\frac{3}{4}'' \times 4''$ long shear studs spaced along all beams connecting to the composite slabs. Trusses support larger spans in atrium and public spaces, while composite beams support the smaller spans for spaces such as hallways, meeting rooms, and back-of-house spaces.

Generally, the second floor consists of W12x26s for the mezzanine area and W24x76s for the blast furnace room. Beams for the third floor are W12x16s, spanning between 18'6" to 22'2". These beams are then supported by trusses, a representative one, Truss F-1A, shown in Figure 7.

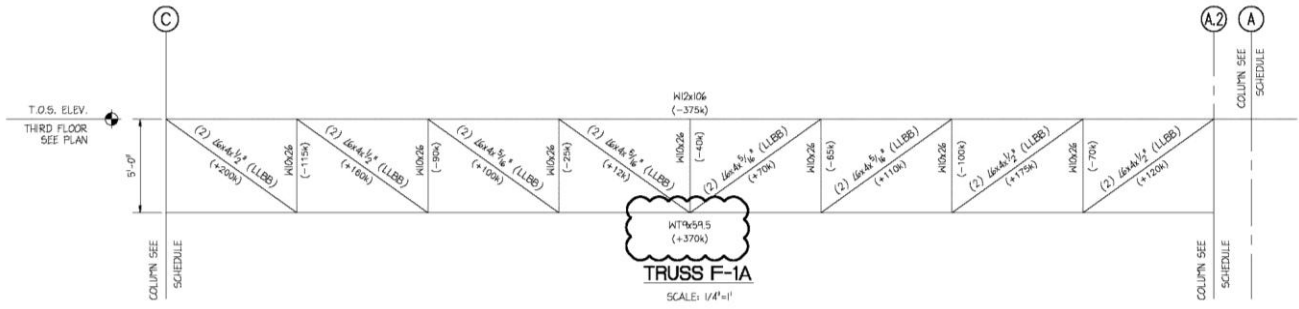

Figure 7 : Third floor representative framing system truss from S2.6.

Framing on the fourth floor is more irregular, as explained previously, due to a large portion of the space open to the third floor, and approximately 25% of the square area excluded due to the mechanical roof. Yet even with the irregular framing plan, the beams are mostly W12x14 for public space, restroom facilities, and storage spaces and W18x35s supporting the green rooms and offices. The mechanical roof has typical framing members of W27x84s supported by Truss R-2, in a similar layout to that of Truss F-1A.

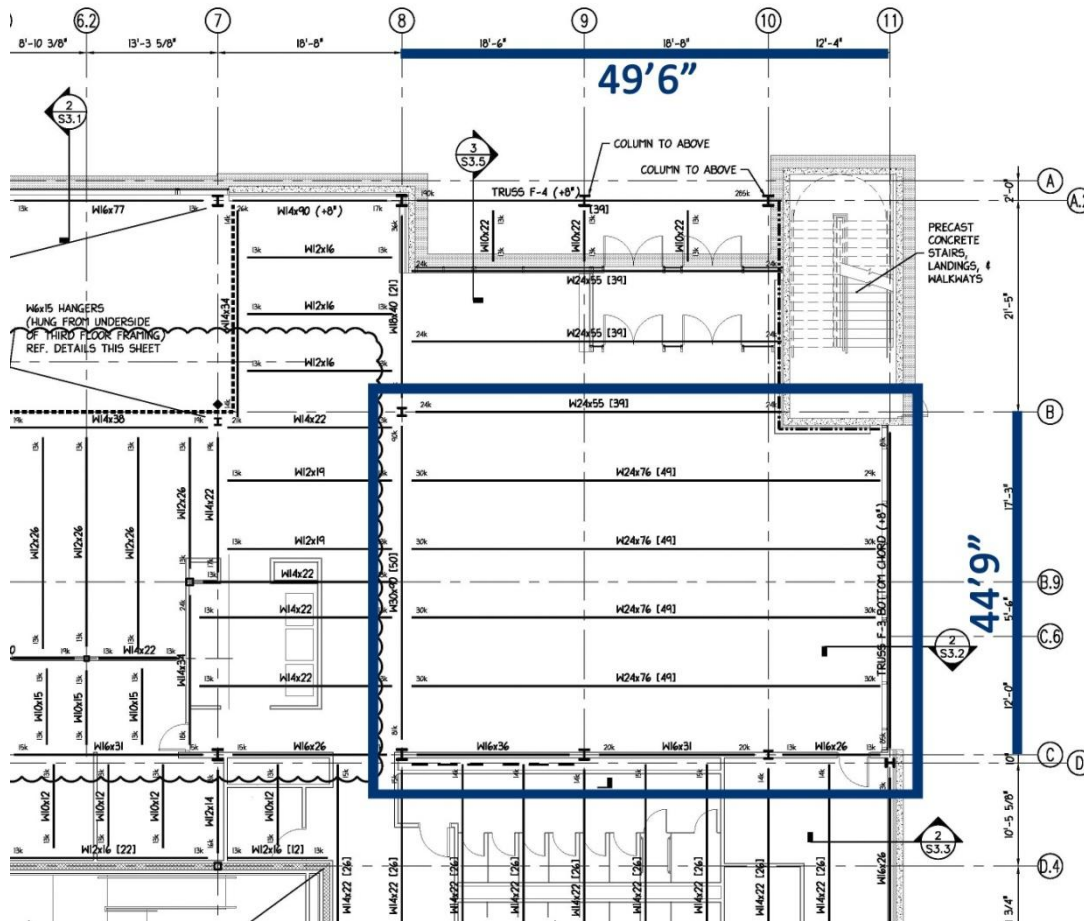

Figure 8: Second floor framing plan, with a representative bay of a typical frame, highlighted in blue, from S2.0

As explained above, this building has inconsistent framing from floor to floor, due to the variability in the space purposes. While no one framing plan is consistent throughout the building, a representative bay is highlighted in Figure 8. This bay is taken from the second floor, which uses the most consistent flooring and framing seen in other portions of the building and on the fourth floor and roofing plans.

The roof framing plan is similar to that of the third floor, both in layout of beams and supporting trusses. Typical beam members are W12x26s, with larger spans along the eastern side of the building leading to larger members.

Above all of the roof framing is the same finish, a fabric-reinforced Thermoplastic Polyolefin (TPO). This involves a light colored fully adhered roofing membrane on lightweight insulated concrete, lending to the LEED Silver status for the SSPAC. See Figure 9 for a cross section of the roof framing and system.

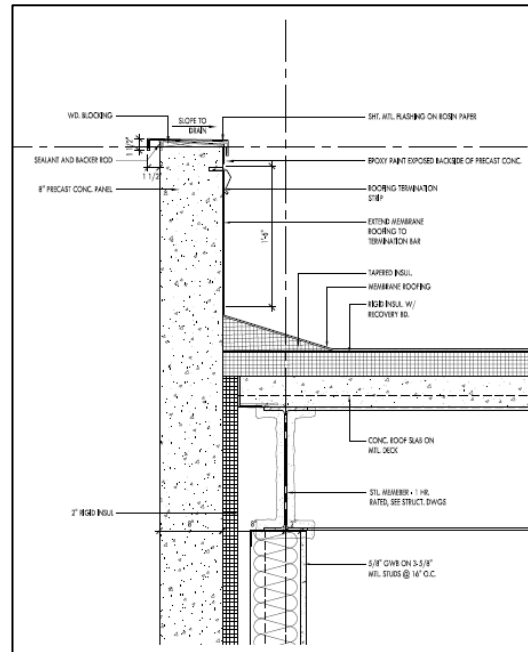

Figure 9 : Cross section of the roofing system.

Supporting the floor systems is a combination of braced frames, columns, and precast panels. Columns are generally W12s, as the structural engineer focused on not only supporting the structure, but keeping the steel consistent dimensions. HSS columns were also used at varying locations, and varied from HSS4x4s to HSS10x10s.

Lateral System

The lateral system of this building varies per direction. In the North-South direction, the lateral system consists of shear walls. These shear walls are comprised of the precast concrete panels found along the exterior of the building, and highlighted in orange in Figure 10. These panels are 8" thick normal weight concrete and are anchored with L5x5x5/16" to the structure for deck support and into the foundation as discussed and detailed previously.

Braced frames along Column Line C in the East-West direction consist of the other component to the lateral framing system. These braced frames are highlighted in blue in Figure 10 and are comprised of W10x33s for diagonal members and W16x36s for horizontal members. An elevation of these lateral systems is included in Figure 10.

The lateral loads on the structure first impact the exterior components and shear walls. Where braced frames are concerned, this load travels through the horizontal members into the diagonal and vertical members. These loads all then continue into the foundation.

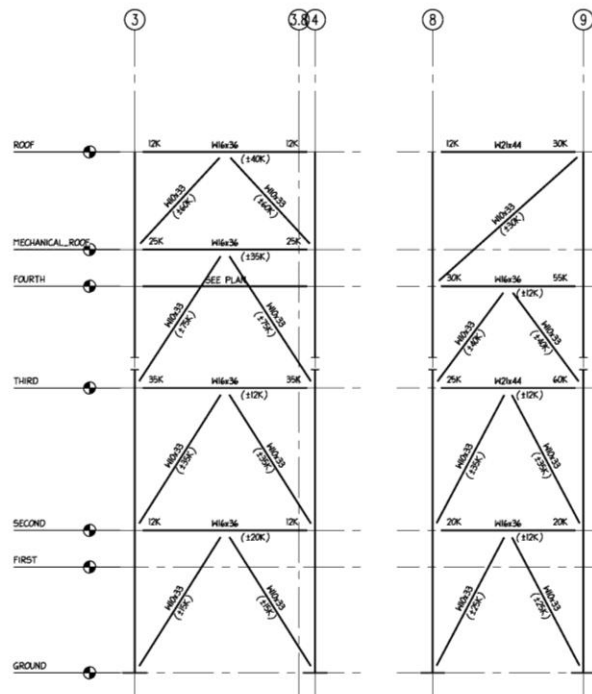
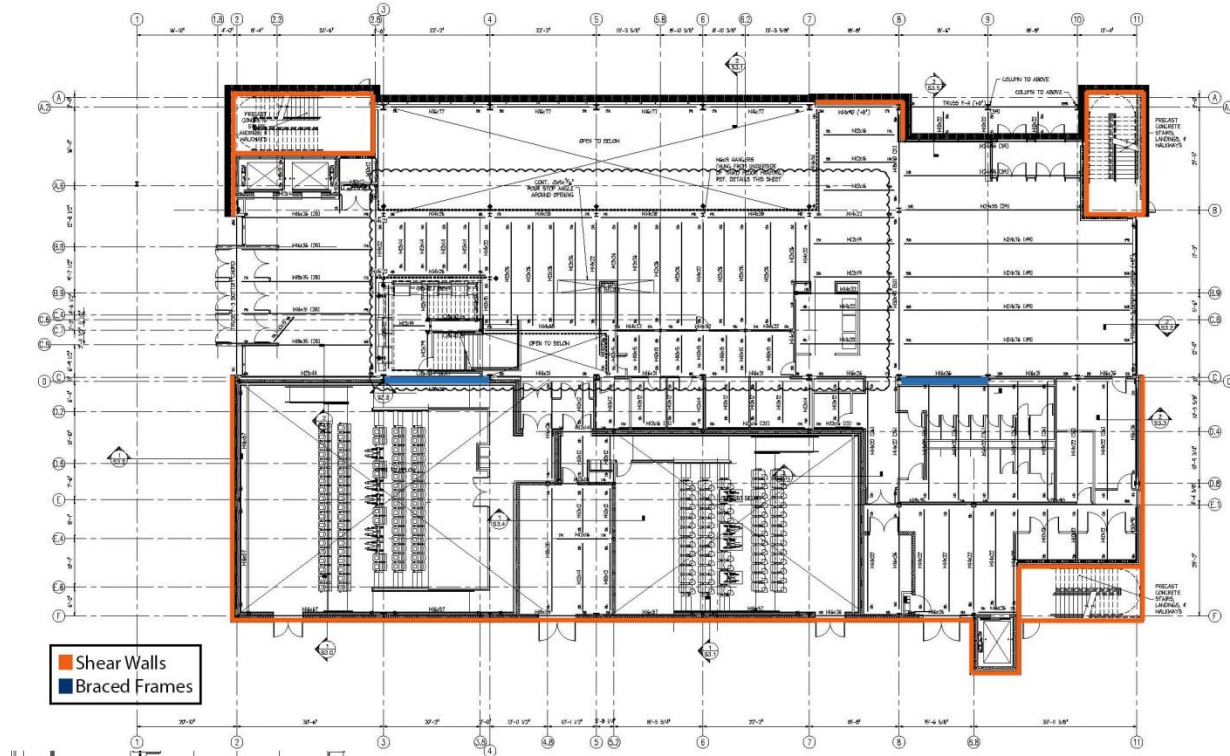

1 ELEVATION AT LINE C
SCALE: 1/8"=1'-0"

- NOTES:
1. CONNECTIONS TO BE DESIGNED FOR FORCES INDICATED BY FABRICATOR'S ENGINEER.
 2. (TK) DENOTES AXIAL FORCE IN MEMBER
(+) TENSION
(-) COMPRESSION
 3. *K DENOTES VERTICAL REACTION ON END OF BEAM

Figure 10: Floor plan highlighting shear walls in orange and braced frames in blue, which contribute to the lateral system, with braced frame elevations shown.

Problem Statement

The SteelStacks Performing Arts Center is designed as a steel gravity system with braced frames acting as the lateral system. This is done effectively in the design by variations in floor plans, bays, structural components to result in a framing consists of a composite decking and steel system. The lateral system is designed as a dual system of shear walls and braced frames for the lateral structural system.

A scenario has been created in which the architect would like to explore an alternative option, and the building is required to be built in reinforced concrete. Through the observations made in Technical Report II, this is a viable system redesign for comparison to the existing system. Other alternatives, such as a precast plank floor system, in Technical Report II have been disqualified due the inconsistency in bay layouts.

The goal of this redesign is to evaluate the benefits of both the existing system and a reinforced concrete system in a comparison of variables such as structural performance, cost, efficiency, aesthetics, and acoustic performance. With a concrete system in place, braced frames will no longer be a viable lateral system option, and therefore, shear walls will be reconfigured and replace braced frames. The gravity system will be evaluated and redesigned, with larger bays being considered for prestressing.

Therefore, a structural system will be designed with the existing gravity system and lateral system being converted to a reinforced concrete system. One ramification that will need to be considered is concerning floor to floor height, and this will be evaluated as part of the redesign. This redesign will impact the aesthetics, and the redesign will be evaluated for architecture and compared to the existing interior spaces. As the gravity system is being redesigned into concrete, these will also be considered a point of evaluation due to the weight impacts on the lateral system. With upper floors being heavier due to acoustic issues, these will be redesigned with acoustics as a consideration. All of this must be achieved while considering impact on the architectural and acoustical qualities of the structure.

Proposed Solution

The redesign of the existing lateral and gravity systems will begin with the consideration of the new shear wall layout along the east-west axis. The new lateral system will be an entirely shear wall system, which will be compared to the existing system for design, construction, and cost while maintaining quality in architecture and acoustics.

The gravity system will then be designed in consideration of cost and weight. Currently, the system is designed for consistent size members for aesthetics, as ceilings are exposed. This redesign will consider the impact of a reinforced concrete system that mainstreams bay layouts on cost of materials and construction. This will influence the architecture and aesthetics of the building, and this impact will be considered and is detailed below in the Breadth section. The structural framing members will be designed using ACI 318-11.

Floor diaphragms will be redesigned while maintaining the necessary floor-to-floor dimensions currently in use, with acoustics and sound isolation being taken into consideration, as acoustics were a controlling factor in creating the existing design. Sound isolation issues will be considered for the mentioned floor and space design. Acoustics will be analyzed for Sound Transmission Contours related to each highlighted space, which will then be utilized for deciding on the most viable floor and space options. The ramifications of the new diaphragm design on the acoustic performance of the spaces are detailed in the Breadth section below.

Breadth Study

Redesign of the SSPAC for the above mentioned limitations will have a direct impact on various other aspects of the building design, as previously stated. These influences include architectural design, acoustics of each of the altered spaces, construction, and mechanical location and vibration issues. The breadths being considered for this proposal are acoustics and architecture and are elaborated below.

Acoustics:

Eliminating braced frames and reconfiguring the framing system for a reinforced concrete system will directly impact the acoustics of the building spaces. Interior walls will need to be reevaluated, and acoustic paneling and materials will be adjusted according to calculation results, to maximize noise isolation. By changing the framing plan arrangement, a primary influence would be on the acoustical performance of each of the spaces where the floor diaphragms are designed for sound isolation. One such space that will be impacted is the third floor Musikfest Café and Stage area. A heavier floor system allows for better sound isolation between floors. By altering the floor system, the chosen design might no longer provide a satisfactory acoustic design. Therefore, the floor diaphragms will be analyzed for effectiveness as sound barriers. To analyze the acoustic performances of the space in each option, Reverberation Time values will be decided per room, based on wall and floor material. Existing and alternatives options will be compared, to conclude on the most viable option according to acoustic performance for the spaces.

Architecture:

By changing the bay layouts and exterior wall system, architectural features will be impacted. By designing shear walls and changing the system to concrete, the interior spaces will be greatly altered, and this fact will need to be considered. The existing architecture also includes exposed ceilings with consistent beam, girder, and truss member sizes for a streamlined look. The proposed redesign continues to include constant sizes, but the use of a different material will impact the aesthetics. The impacts of these system alterations will be visually considered through the use of a Revit model, giving the ability to compare the existing with the new design more exhaustively. A final architectural view will be provided to display the impacts of the design.

MAE Component

As a requirement for the MAE program, the coursework from multiple MAE classes will be incorporated into the completion of this thesis. For completion of the depth, a structural building model will be built in RAM Structural System. This follows the material learned in AE 530, *Computer Modeling of Building Structures*. Use of a detailed structural model will aid in the analysis of building and member loads. Concepts implemented include panel zones, and rigid diaphragm constraints. With the further details of the structural system redesign, material from CE 543, *Prestressed Concrete Behavior and Design*, will also be applied the investigation of the gravity system design. Larger bays will be evaluated for the benefits of designing these bays for prestressing, and will be detailed for the appropriate design results.

Tasks & Tools

- I. Structural System – Lateral System
 - a. Establish most effective location for additional shear walls
 - i. Consider existing wall and column line locations for shear wall locations
 - ii. Take architectural features (walls, windows, spaces) into consideration
 - b. Establish lateral loads on system
 - c. Using a computer modeling program, determine member loads, confirming with hand calculations
 - d. Redesign lateral system for ordinary reinforced concrete shear walls
- II. Structural System – Gravity System
 - a. Adjust column lines & bay configurations, due to impact from additional walls
 - i. Reconfigure diaphragm for more effective lateral load transfer
 - ii. Consider ramifications of this on space requirements, if any
 - b. Analyze loading from above spaces on beams and girders
 - c. Design diaphragms
 - i. For larger spans, consider benefits of prestressed concrete design
 - d. Design beams/girders/columns in typical bay by hand for loading
 - e. Reconfirm with building model program
 - f. Consider ramifications on foundation design
- III. Breadth II: Acoustics: Musikfest Café and Stage Area
 - a. Research impact of different floor systems on acoustics
 - b. Compare options through use of acoustics analysis for sound isolation
 - c. Include this in analysis and performance summary of compared systems
- IV. Breadth X: Architectural
 - a. Build initial Revit model for direct comparison of existing building design with new lateral and gravity systems
 - b. Look at primary façade impacts – compare to existing
 - i. Evaluate issues new structural design may bring
 - c. Look at impact on primary interior spaces via comparison of Revit Models
 - i. Impact of beam and girder sizing
 - ii. Impact of column and shear wall locations
 - d. Adjust wall and framing configuration for major architectural issues to minimize impacts, if necessary

Timetable

A weekly schedule has been developed, summarizing the main tasks discussed above, with semester and target dates provided to give a representation of individual-led goals throughout the thesis process.

		Proposed Thesis Semester Schedule January 2013-April 2013																		
		1/28/13 Milestone 1	2/11/13 Milestone 2	3/1/13 Milestone 3	3/11/13 Initial Finish Goal	3/25/13 Milestone 4	Final Report - April 3rd		Final Report	Update CPEP and Report										
7-Jan-13	14-Jan-13	21-Jan-13	28-Jan-13	4-Feb-13	11-Feb-13	18-Feb-13	25-Feb-13	4-Mar-13	11-Mar-13	18-Mar-13	25-Mar-13	1-Apr-13	8-Apr-13	15-Apr-13	22-Apr-13					
Establish location for additional shear walls		Build structural model & analyze loads		Confirmed hand calc loads via model		Column lines & bays		Evaluated & design diaphragms		Design beams, girders, columns		Run acoustics model for sound isolation		Compare options & design diaphragms		Design Lateral System & confirm via model		Senior Banquet April 26th		
																		Faculty Jury Presentations April 8-12		
																		ABET Assessments, Finals Presentations		
																		Update CPEP and Report		
																		Jury Presentations		
																		Finalize Report		
																		Start Presentation		
																		Compare differences & adjust impact accordingly		
																		Build architectural model		
																		Start Report		
																		Milestones		
1	Loads finalized, layout evaluated																		Thesis Topics	
2	Breadth I: Acoustics Finalized; gravity system design started																		Depth: Entirely Steel Lateral System	
3	Completion of Revit Model; lateral system design started																		Breadth I: Acoustics	
4	Completion of Breadths																		Breadth II: Architectural Design	

Conclusion

A scenario has been developed in which the architect desires the exploration of a reinforced concrete structural system. A comparison of the existing system and the redesigned concrete system will be developed for a thorough understanding of the benefits and disadvantages of each. The structural depth solution to this scenario implements additional shear walls to replace the existing braced frames as part of the lateral system. The gravity system will be redesigned as a reinforced concrete system, with minimization of cost and waste as considerations throughout redesign. Floor diaphragms will be evaluated in larger bays for the use of prestressed concrete design.

The solution for the structural redesign will impact the architecture and acoustics of the spaces. With both aesthetics and acoustics being important factors in the original design, they are also necessary considerations for the redesign. Public spaces will be impacted by the structural changes due to acoustic issues, such as in the stage and Musikfest Café area. With the floor system being redesigned, acoustical performance of the existing and new designs will be studied and taken into account in a comparison of the final gravity system. In architectural design, the public spaces and facade will be altered due to the wall and gravity systems being redesigned. For this to be thoroughly evaluated, an architectural model will be utilized to compare the existing and redesigned spaces, with major impacts being studied for possible alteration.

In addition, MAE coursework will be included in this thesis project, and has been incorporated into this proposal. Material from AE 530, *Computer Modeling of Building Structures*, and CE 543, *Prestressed Concrete Behavior and Design*, will be utilized to provide a more complete project, and the implementation has been elaborated on in this report.